



AT A GLANCE

WORKFLOWS

YOUR  
PARTNER

ANALYSIS

APPLICATION  
NOTES

RESOURCES

---

# Protein Solutions *eBook*

---

the  
**Analytical Scientist** X

**ThermoFisher**  
SCIENTIFIC







## Protein Therapeutics: *At a Glance*

*Protein therapeutics are a type of biotherapeutics derived from genetically engineered human proteins. They offer several advantages over small-molecule drugs, allowing for more precise targeting of complex functions.*

Compared to chemical drug production, the production process for protein-based therapeutics is intricate and variable, with a higher risk of product degradation and contamination. The final product is fragile and can be affected by factors like temperature, storage duration, denaturants, solvents, oxygen, and pH changes.

As a result, protein biologics require strict controls in manufacturing, transport and storage. An array of analytical approaches and workflows facilitate comprehensive characterization, allowing for full product understanding which can save significant time and development costs.

Throughout process development and manufacturing, these analytical tools are required for reliable monitoring of product microheterogeneity ensuring drug safety and efficacy.

This eBook will provide a comprehensive explanation of the different workflows specifically designed for protein analysis, highlighting the benefits that each workflow offers.







AT A GLANCE

WORKFLOWS

YOUR PARTNER

ANALYSIS

APPLICATION NOTES

RESOURCES

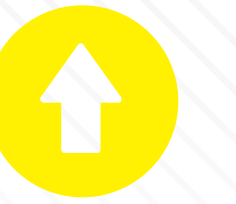

# Protein Therapeutics: *Workflows*

Use the wheel to navigate  
to your area of interest

[Intact Protein Analysis](#)  
[Native Intact Analysis](#)  
[Aggregate Analysis](#)  
[Subunit Analysis](#)

[Glycan Analysis](#)

[Higher Order Structure Analysis](#)

[Peptide Mapping](#)  
[Multi-Attribute Method](#)  
[Host Cell Protein Analysis](#)

[Charge Variant Analysis](#)

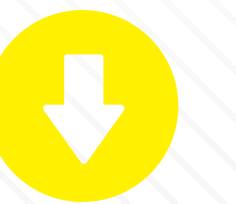
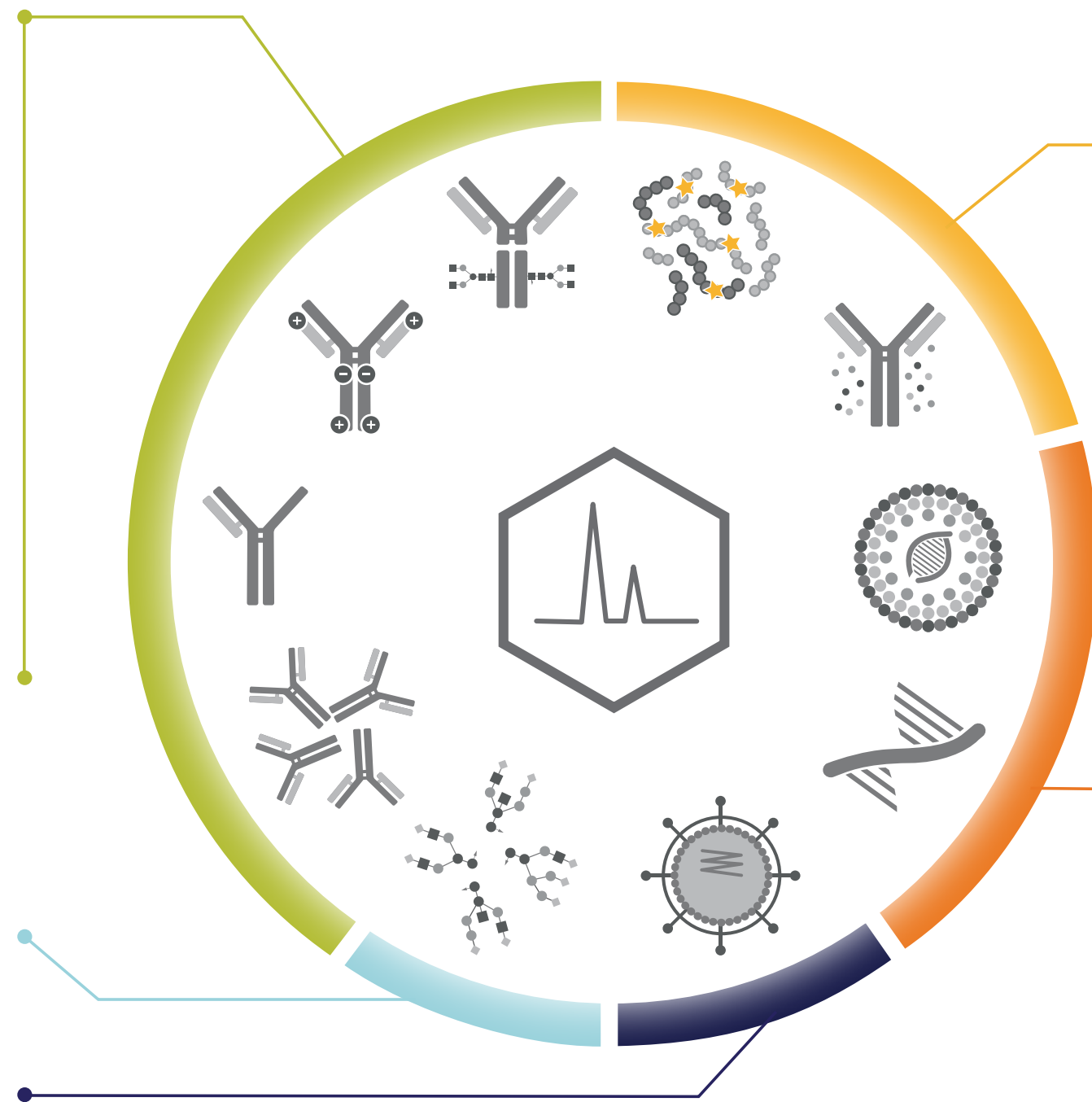



AT A GLANCE

WORKFLOWS

YOUR PARTNER

ANALYSIS

APPLICATION NOTES

RESOURCES



# Your Partner for Every Step in your Protein Therapeutics Journey

*From discovery to commercialization, Thermo Fisher Scientific provides expertise and a superior array of scalable tools, services, and support, designed to deliver high-quality results and accelerate your productivity and innovation*

Early Discovery and Research



*high-throughput capabilities and versatile, advanced tools*

Product characterization



*advanced tools to answer in-depth molecular questions*

Process and Analytical Development



*robust and reproducible analyses to monitor molecular attribute changes with speed and confidence*

Quality Control and Manufacturing



*reproducible, robust, GMP compliance- ready methods*

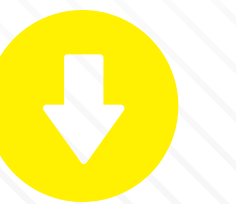





AT A GLANCE

WORKFLOWS

YOUR PARTNER

ANALYSIS

APPLICATION NOTES

RESOURCES

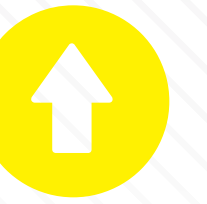

## Intact Protein Analysis

In intact protein analysis there is a need for a more efficient approach that saves time on sample preparation and offers simple data analysis.

The ideal solution provides high throughput, information-rich data, and fast assessment of post-translational modification levels.







AT A GLANCE

WORKFLOWS

YOUR PARTNER

ANALYSIS

APPLICATION NOTES

RESOURCES



# Intact Protein Analysis

*Efficient intact protein analysis for rapid assessment enabling confident identification*

There is a need for a more efficient protein analysis approach that saves time on sample preparation and offers simple data analysis. The ideal solution provides high throughput, information-rich data, and fast assessment of post-translational modification levels.

## Value-added workflow benefits

- Direct infusion techniques or separation allow intact protein analysis
- Screen, identify, and characterize intact proteins with higher productivity and confidence using the Intact Protein workflow in Thermo Scientific™ BioPharma Finder™ software
- BioPharma mass extension available for Orbitrap Exploris 240 and 480
- Quickly confirm intact protein molecular weight and determine glycoform heterogeneity of biopharmaceuticals

## LINKS

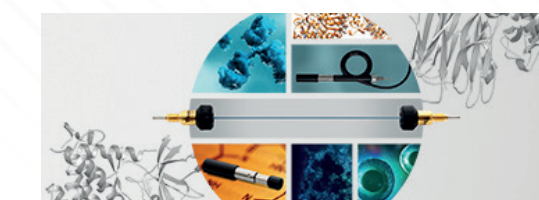

### Webinar

*Workflows for robust and sensitive separation of mAbs, intact proteins at subunit and peptide level using capillary chromatography by LC-MS*

Learn more about intact protein analysis

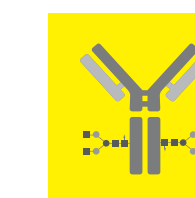

## Early Discovery and Research

## Development

## QC

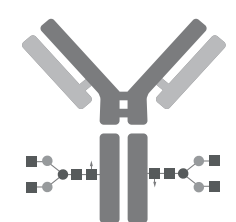

Biotherapeutic protein

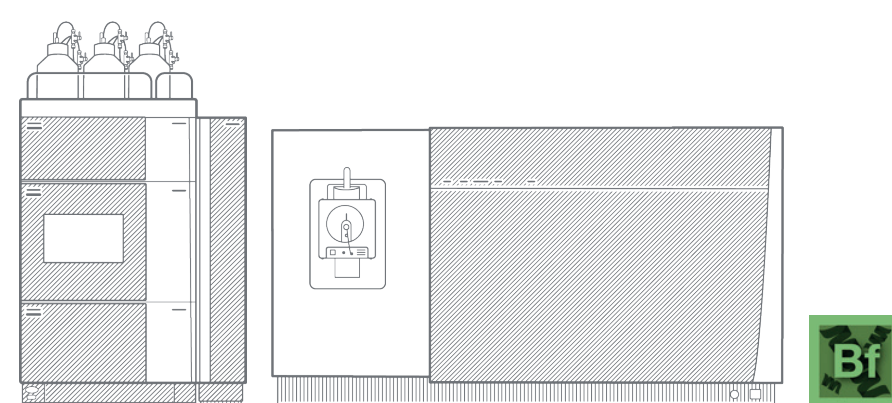

Thermo Scientific™ Orbitrap Ascend™ Tribrid MS

CID and HCD, optionally with UVPD, ETD, PCTR, can be used in any MS stage, followed by mass analysis in either the ion trap or ultra-high resolution Orbitrap mass analyzer

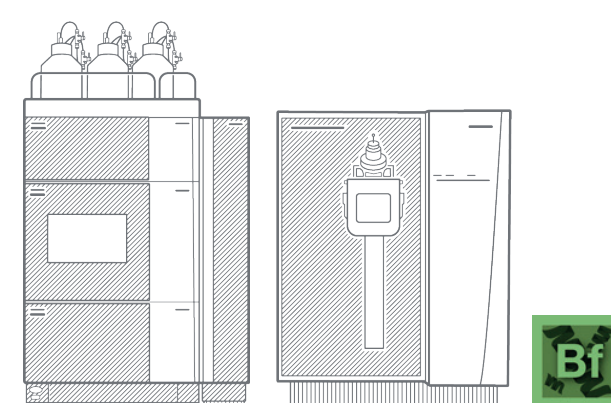

Thermo Scientific™ Orbitrap Exploris™ 480 MS

Intuitive instrument control for easy execution of analysis  
Easy-to-use software for data processing

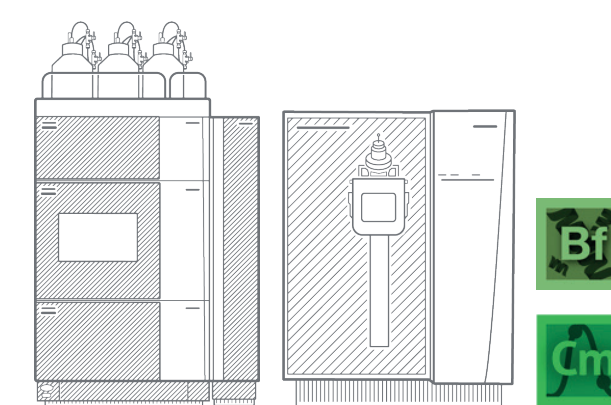

Thermo Scientific™ Orbitrap Exploris™ 240 MS

Excellent sensitivity, allows the use of much less sample for high quality intact MS analysis

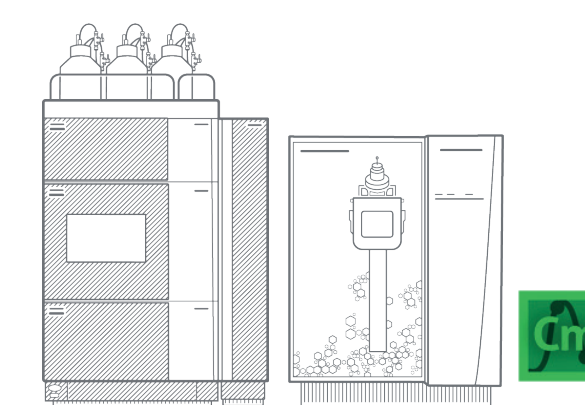

Thermo Scientific™ Orbitrap Exploris™ MX MS

Built for usage in the routine environment  
Complemented by compliance-ready software  
Thermo Scientific™ Chromeleon™







AT A GLANCE

WORKFLOWS

YOUR PARTNER

ANALYSIS

APPLICATION NOTES

RESOURCES

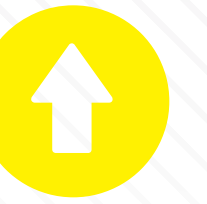

# Intact Protein Analysis Under Near-Native Conditions

The term 'native' describes the biological status of the analytes in solution prior to the ionization event.

It is imperative that conditions such as pH and ion source parameters are controlled to maintain the native folded state of the biologic protein.

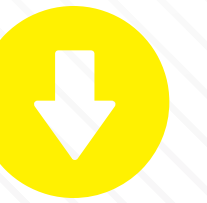





AT A GLANCE

WORKFLOWS

YOUR PARTNER

ANALYSIS

APPLICATION NOTES

RESOURCES

# Intact Protein Analysis Under Near-Native Conditions

*Analysis of intact proteins and protein-complexes, in their true biological states*

Analyzing complex therapeutic proteins like antibody-drug conjugates (ADCs) is a significant challenge. The Thermo Scientific Orbitrap Exploris mass spectrometers, coupled with size

exclusion or ion exchange chromatography and compatible buffers, enable routine intact protein analysis under native conditions.

### Value-added workflow benefits

- Use Thermo Scientific MAbPac SEC-1 Size Exclusion Columns for high-resolution separation of monoclonal antibody (mAb) analysis, including monomers and aggregates
- BioPharma option to extend mass range available for the Orbitrap Exploris 240 and 480 MS systems
- Excellent mass spectrometric data, intuitive instrument

- control and easy-to-use software for data processing
- Q Exactive™ UHMR Hybrid Quadrupole Orbitrap™ Mass Spectrometer offers precise mass determination, peak interference mitigation, and the ability to study heterogeneous protein assemblies

## EARLY DISCOVERY AND RESEARCH

## DEVELOPMENT

## QC

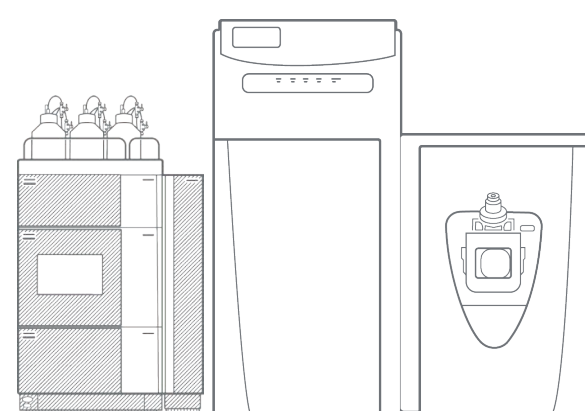
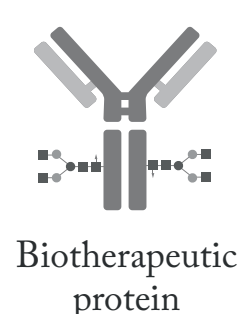

Thermo Scientific™ Q Exactive™ UHMR MS

The first UHMR MS to combine substantially increased sensitivity and mass resolution at high m/z, MS2, and psuedo-MS3 capabilities in a single platform

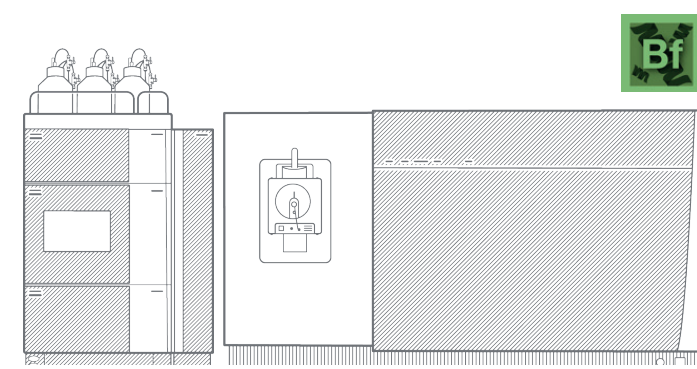

Thermo Scientific™ Orbitrap Ascend™ Tribrid MS

Advanced MS capabilities and optional mass range of up to 16'000 m/z allow scientists to take advantage of versatile fragmentation techniques and advanced ion reaction techniques like proton transfer charge reduction

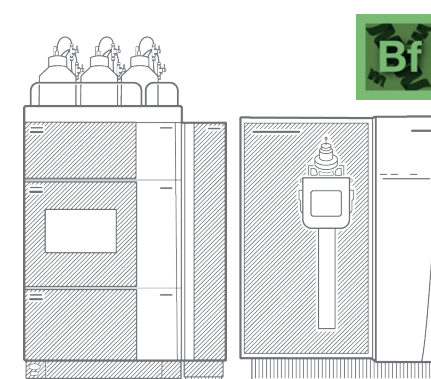

Thermo Scientific™ Orbitrap Exploris™ 480 MS

Intuitive instrument control for easy execution of analysis  
Easy-to-use software for data processing

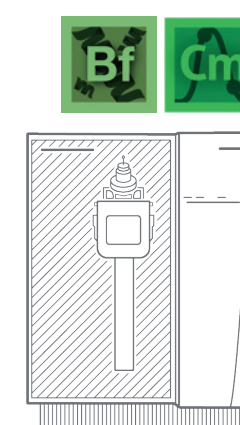

Thermo Scientific™ Orbitrap Exploris™ 240 MS

Excellent sensitivity, allowing the use of much less sample for high quality native MS analysis

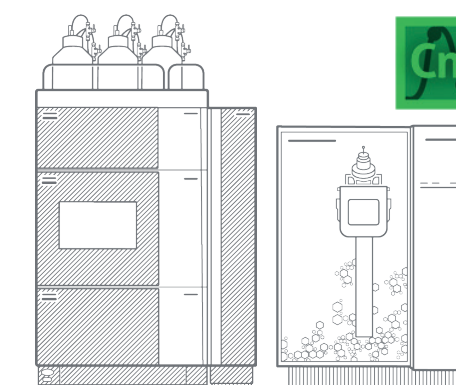

Thermo Scientific™ Orbitrap Exploris™ MX MS

Built for usage in the routine environment. Complemented by compliance-ready software Thermo Scientific™ Chromeleon™



## LINKS



### Webinar

*NIBRT: Ion exchange chromatography hyphenated to mass spectrometry for fast and robust characterization of mAb variants under native conditions*

Learn more about intact protein analysis

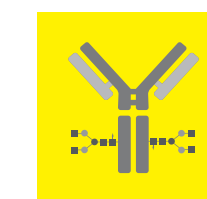





AT A GLANCE

WORKFLOWS

YOUR PARTNER

ANALYSIS

APPLICATION NOTES

RESOURCES

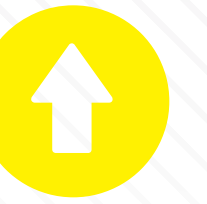

## Aggregate Analysis

The consistent quality of biologic products must be ensured by monitoring protein aggregates throughout the production process, as aggregates can have serious negative effects, including loss of efficacy of therapeutic treatment and cytotoxicity, and may cause an undesired immune response.

Failure to monitor protein aggregates can result in incorrect drug dosage, decreased solubility, and activity loss.

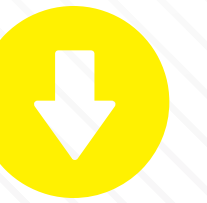
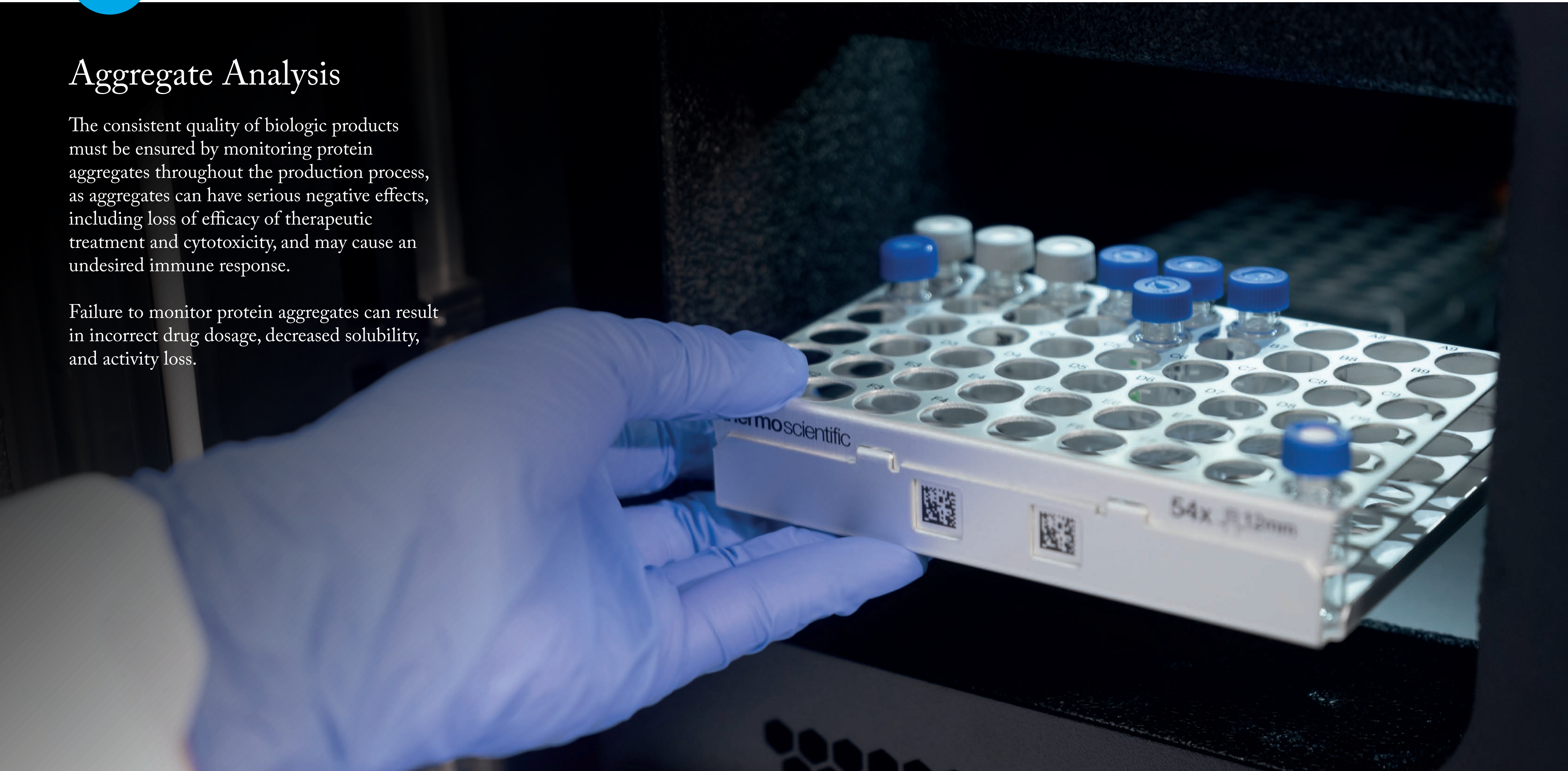





AT A GLANCE

WORKFLOWS

YOUR PARTNER

ANALYSIS

APPLICATION NOTES

RESOURCES



# Aggregate Analysis

*High resolution separation of monomers and aggregate peaks*

The consistent quality of biologic products must be ensured by monitoring protein aggregates throughout the production process, as aggregates can have serious negative effects. Failure to monitor protein aggregates can result in incorrect drug dosage, decreased solubility, and activity loss.

### Value-added workflow benefits

- High resolution separation of fragments, monomers and aggregates
- BioPharma option to extend mass range available for the Orbitrap Exploris 240 MS
- Thermo Scientific™ Vanquish™ Duo UHPLC system for Dual LC provides simple and rapid high-throughput analysis of aggregates
- Compliance-ready analytical setup using Thermo Scientific™ Chromeleon™ software for the monitoring stage

### LINKS

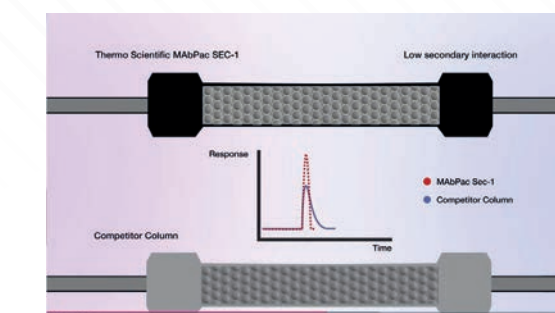

Application Note Video  
*A universal  
 Chromatography  
 Method for Aggregate  
 Analysis of Monoclonal  
 Antibodies*

### CHARACTERIZATION

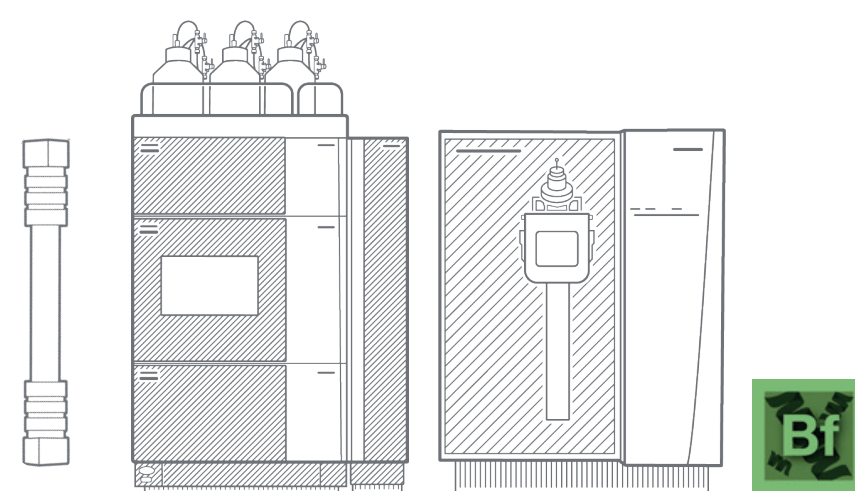
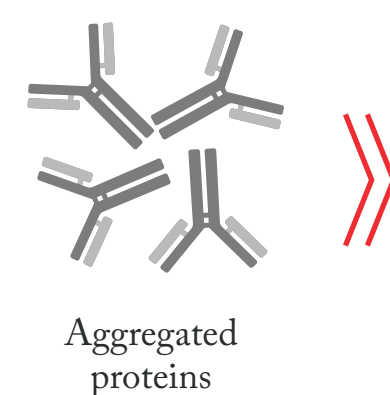

Thermo Scientific™ Vanquish™ UHPLC System &  
 Thermo Scientific™ Orbitrap Exploris 240 MS

Aggregate analysis by HRAM MS facilitates the analysis of the proteins in their native form, without the need for sample preparation, while providing information on aggregation and fragmentation

### ROUTINE MONITORING

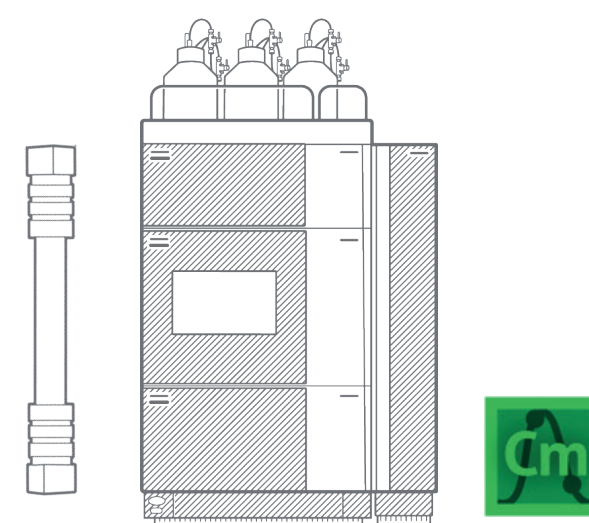

Thermo Scientific™ Vanquish™ Duo UHPLC System

The Vanquish Duo UHPLC system provides two independent flow paths connected to two individual detectors. This unique system lets you run two analyses in parallel, either identical or not, on a single system to double throughput, accelerate method development, and improve sample characterization

Learn more  
 about aggregate  
 analysis

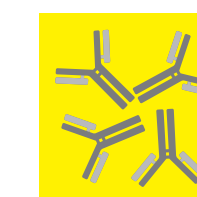





AT A GLANCE

WORKFLOWS

YOUR  
PARTNER

ANALYSIS

APPLICATION  
NOTES

RESOURCES

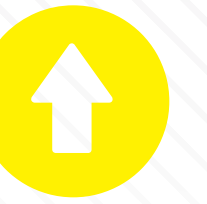

## Subunit Analysis

Subunit analysis involves faster sample preparation, and simplified data interpretation compared to peptide mapping or bottom-up characterization approaches and provides simultaneous characterization of multiple attributes of antibodies at domain levels.

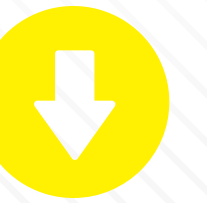





AT A GLANCE

WORKFLOWS

YOUR PARTNER

ANALYSIS

APPLICATION NOTES

RESOURCES



# Subunit Analysis

*Easy deconvolution by harnessing the power of Thermo Scientific BioPharma Finder Software*

Monoclonal antibody (mAb) subunit analysis involves the antibody fragmentation through digestion and reduction of IgG antibody molecules. The cysteine protease produced by *S.pyogenes*, known as IdeS, is highly specific.

IdeS digestion followed by reduction generates three subunits

that are readily separated by reversed-phase (RP) UHPLC using Thermo Scientific MAbPac RP columns. Deconvolution of subunit mass spectrometry (MS) spectra is easy with powerful Thermo Scientific BioPharma Finder software.

### Value-added workflow benefits

- Subunits are readily separated by reversed-phase (RP) UHPLC using Thermo Scientific MAbPac RP columns
- Deconvolution of subunit mass spectrometry (MS) spectra is easy with powerful Thermo Scientific BioPharma Finder software

- Thermo Scientific™ Pierce Fab Preparation Kit uses immobilized pepsin protease to digest human or mouse IgG antibodies to make separate Fab and Fc antibody fragments

## LINKS



### Webinar

*Workflows for robust and sensitive separation of mAbs, intact proteins at subunit and peptide level using capillary chromatography by LC-MS*

## CHARACTERIZATION

## ROUTINE MONITORING

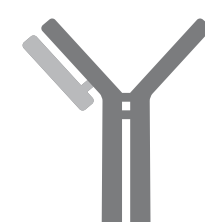

Subunits

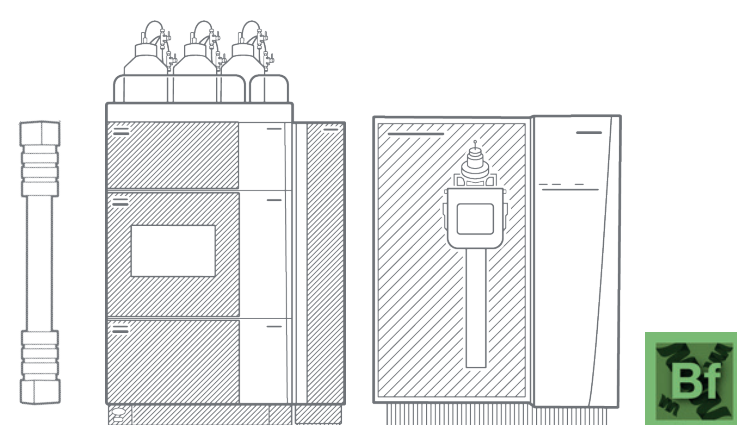

Vanquish UHPLC System & Orbitrap Exploris 240 MS

The extreme resolving power of the Thermo Scientific Orbitrap mass analyzer ensures isotopic resolution of monoclonal antibody subunits and facilitates middle-down sequencing.

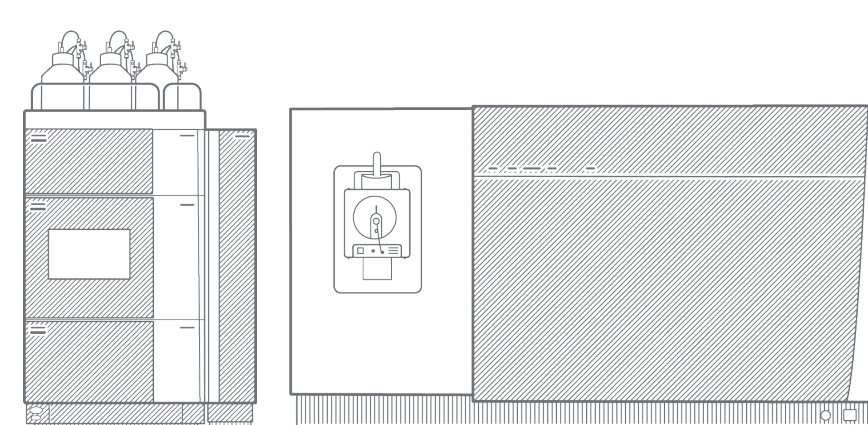

Thermo Scientific™ Orbitrap Ascend™ Tribid MS

Quantify more samples at lower concentrations using faster acquisition, while achieving greater coverage using a revolutionary new hardware design featuring dual ion routing multipoles

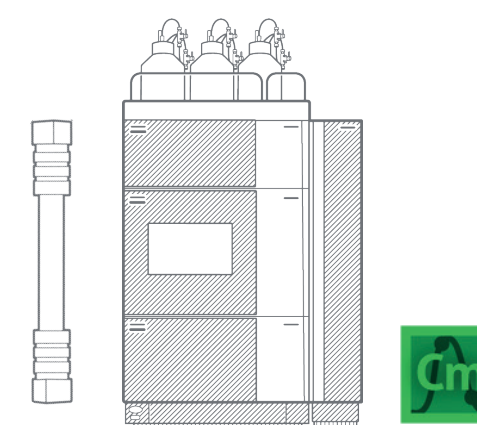

Thermo Scientific™ Vanquish UHPLC System

Take advantage of MAbPac SEC-1 columns which offer superior, reproducible separation of monomers, aggregates, and fragments resulting from proteolysis







AT A GLANCE

WORKFLOWS

YOUR PARTNER

ANALYSIS

APPLICATION NOTES

RESOURCES



## Higher Order Structure Analysis

Hydrogen deuterium exchange (HDX) mass spectrometry (MS) is a powerful tool for studying the dynamics of higher order structure of protein-based therapeutics.

Full structural characterization is critical in biopharmaceutical development where the subtle but critical local conformational changes can impact safety and efficacy.







AT A GLANCE

WORKFLOWS

YOUR PARTNER

ANALYSIS

APPLICATION NOTES

RESOURCES

# Higher Order Structure Analysis

*A robust method for the analysis of protein conformation, conformation dynamics, and protein-protein interactions*

A robust method for the analysis of protein conformation, conformation dynamics, and protein-protein interactions Full structural characterization is critical where local conformational

changes can impact safety and efficacy. Hydrogen deuterium exchange (HDX) mass spectrometry (MS) is a powerful analytical approach for studying the dynamics of higher order structure of protein-based therapeutics. We offer a unique total solution for your HDX workflow.

### Value-added workflow benefits

- Sample preparation and labelling is made easy by our partners, Trajan Scientific and Medical. Trajan's LEAP HDX sampler system enables automated labelling and digestion

- The Vanquish Neo UHPLC system combines an unrivaled degree of innovation to deliver 24/7 reproducible separations of complex mixtures at maximum performance for a variety of high-sensitivity LC-MS workflows
- Thermo Scientific BioPharma Finder software supports all HDX-MS data analysis, including peptide identification, PTM analysis and HDX-unique protection factor plots at the single residue level

## EARLY DISCOVERY AND RESEARCH

## DEVELOPMENT

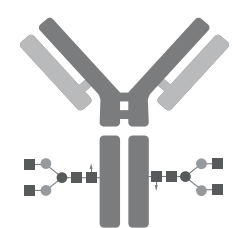

Biotherapeutic protein

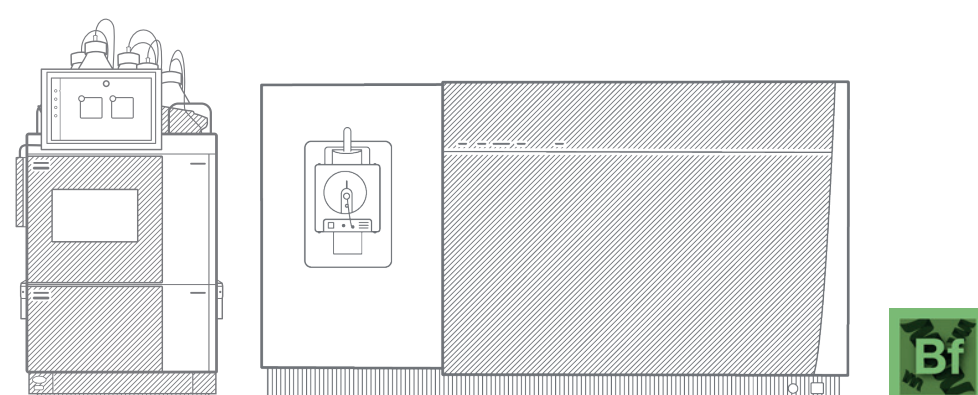

Thermo Scientific™ Neo™ Nano LC & Orbitrap Ascend Tribid MS

Delivering the ultimate flexibility to expand experimental scope, and with built-in intelligence, Orbitrap Ascend Tribid Mass Spectrometer ensures the highest data quality for HDX-MS experiments

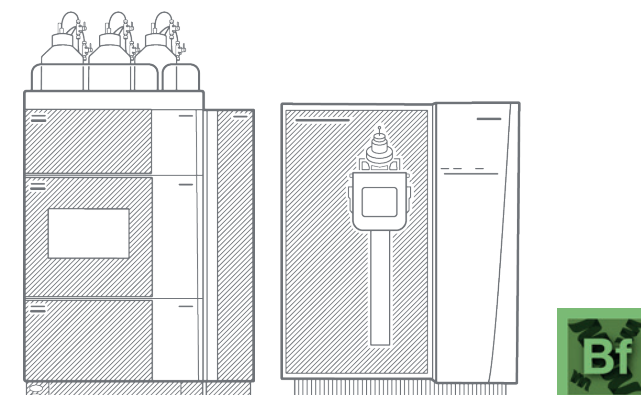

Orbitrap Exploris 480 MS

Intuitive instrument control for easy execution of analysis  
Easy-to-use software for data processing

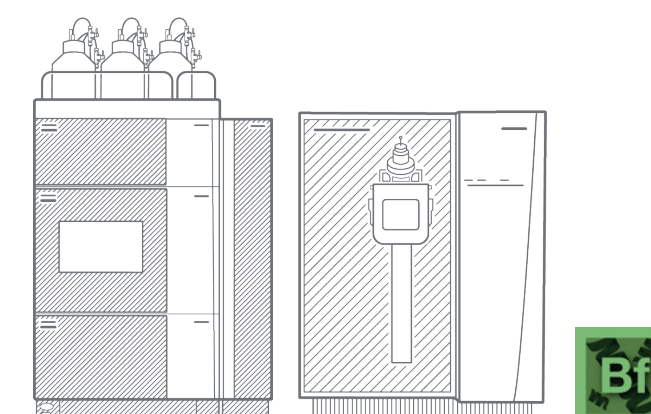

Orbitrap Exploris 240 MS

Thermo Scientific™ Orbitrap Exploris™ 240 mass spectrometer fast tracks your path to high-confidence data and identification



## LINKS

Webinar  
*Dr Patrick Griffin - Hijacking Molecular Plasticity to Fine Tune Nuclear Receptor Signaling: Chemical Biology and Precision Therapeutics*



Learn more about higher order structure analysis

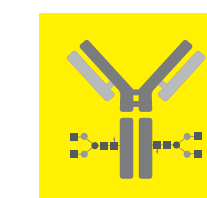





AT A GLANCE

WORKFLOWS

YOUR PARTNER

ANALYSIS

APPLICATION NOTES

RESOURCES

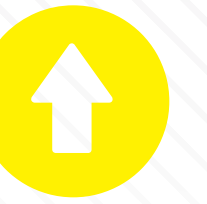

## Charge Variant Analysis

The analysis of charged variants is a regulatory requirement for bio-therapeutic proteins. These large heterogeneous molecules can be subject to a variety of enzymatic post-translational modifications during manufacture, such as glycosylation and lysine truncation.

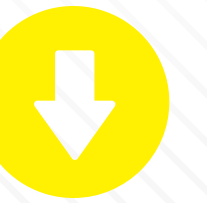





AT A GLANCE

WORKFLOWS

YOUR PARTNER

ANALYSIS

APPLICATION NOTES

RESOURCES



# Charge Variant Analysis

*Full solutions from mobile phase preparation to purpose-built software*

Heterogeneity of monoclonal antibodies must be monitored and revealed by charge sensitive techniques. Two workflows specific to your needs:

1. Separation by charge followed by mass spectrometry (CVA-MS) allows for characterization of post-translational modifications (PTMs) at the intact protein level.
2. Salt gradient cation-exchange chromatography can be used to monitor mAb charge variants.

### Value-added workflow benefits

- Simplified and fast ion exchange analysis (IEX) of charge variants using a pH gradient

- Obtain fast and highly robust, reproducible HPLC gradients using Thermo Scientific™ CX-1 pH gradient buffer kits. The CX-1 buffers save time in method development, facilitate method transfer to QA/QC
- The Orbitrap Exploris 240 MS offers high sensitivity, allowing for the detection and quantification of low abundance charge variants
- Vanquish UHPLC systems offer dependable, flexible, and productive separations

## LINKS



### Webinar

*Taking Charged Variant Analysis to the next level*

Learn more about charge variant analysis

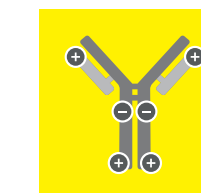

## CHARACTERIZATION

## ROUTINE MONITORING

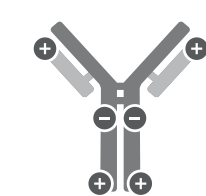

Biotherapeutic proteins

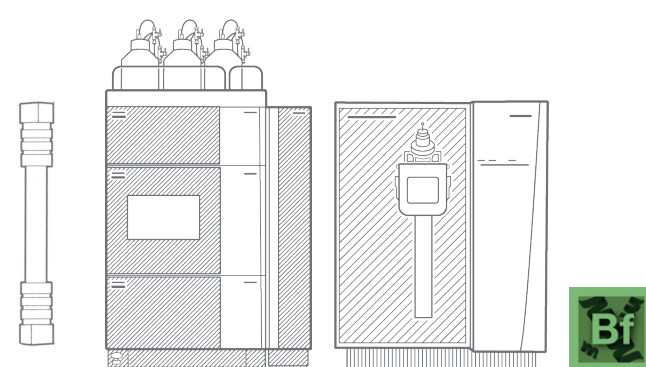

Thermo Scientific™ Vanquish™ UHPLC System & Orbitrap Exploris 240 MS

Speed and accuracy are key criteria for laboratories performing charge variant profiling with an out of the box sample capacity of 216 samples. The Vanquish UHPLC system and the Orbitrap Exploris 240 MS offers the speed and accuracy required for charge variant profiling

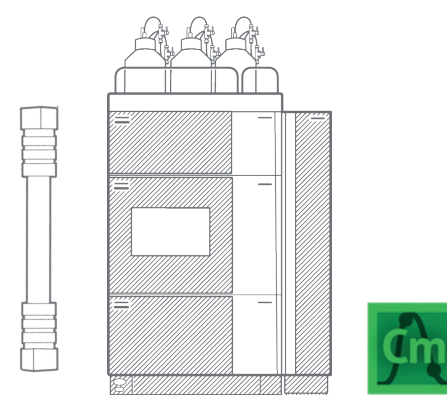

Vanquish™ UHPLC System

Obtain new benchmarks in accuracy, precision and sensitivity in charge variant analysis with the Thermo Scientific™ Vanquish™ UHPLC systems. Providing biocompatibility with a state-of-the-art quaternary or binary high-pressure solvent blending, these ultra-high performance liquid chromatography systems share all Vanquish values, such as a design focused on uptime, robustness and reliability







AT A GLANCE

WORKFLOWS

YOUR PARTNER

ANALYSIS

APPLICATION NOTES

RESOURCES

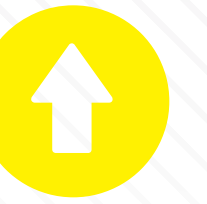

## Peptide Mapping

Accurate peptide mapping is crucial for determining sequence coverage, identifying and quantitating post-translational modifications, determining disulphide bonds and identifying sequence variants of proteins.

Failure to accurately perform peptide mapping can result in incomplete or incorrect protein characterization, compromising the safety and efficacy of biologic products

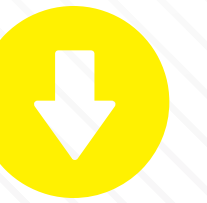





AT A GLANCE

WORKFLOWS

YOUR PARTNER

ANALYSIS

APPLICATION NOTES

RESOURCES

# Peptide Mapping

*High throughput peptide mapping with Vanquish Duo UHPLC system*

Accurate peptide mapping is crucial for determining sequence coverage, identifying and quantitating post-translational modifications, determining disulphide bonds, identifying sequence variants, and performing de novo sequencing of proteins. Failure to accurately perform peptide mapping can result in incomplete or

incorrect protein characterization, compromising the safety and efficacy of biologic products.

### Value-added workflow benefits

- Automation options and kit-based protein digestion for the reproducible results
- High throughput peptide mapping with Vanquish Duo UHPLC system
- Complete product characterization: Sequence coverage, PTMs, Disulfide bonds and Sequence variants

## CHARACTERIZATION



Peptides

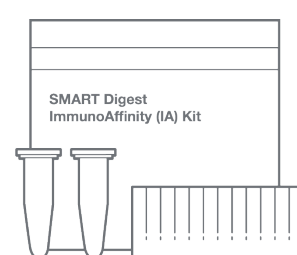

Thermo Scientific™ KingFisher™ Duo Prime Purification System

Thermo Scientific™ SMART Digest™ Kit provides fast and simple protein digestion with high reproducibility and sensitivity, in a format that's compatible with automation

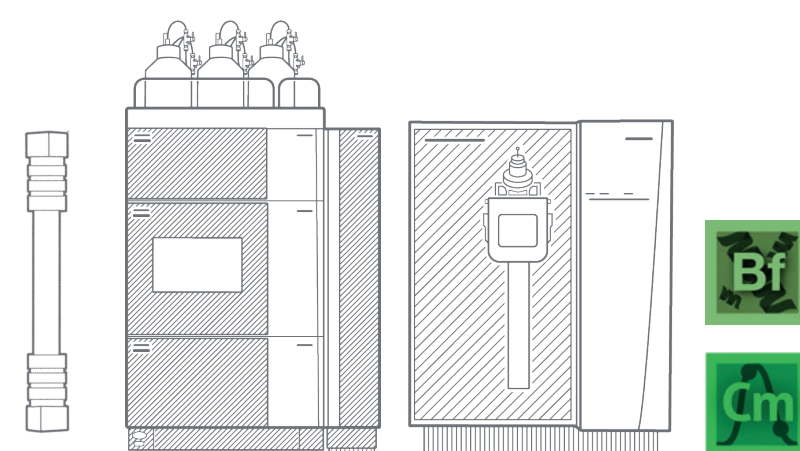
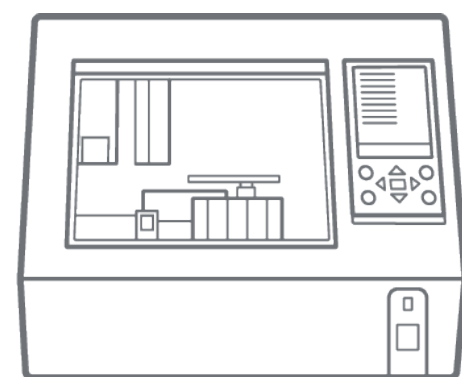

Vanquish Duo UHPLC System & Orbitrap Exploris 240 MS

The Vanquish Duo allows for tandem LC-MS. With this approach, a greater number of sample injections can be performed in the same timeframe, enhancing throughput and significantly reducing MS idle time

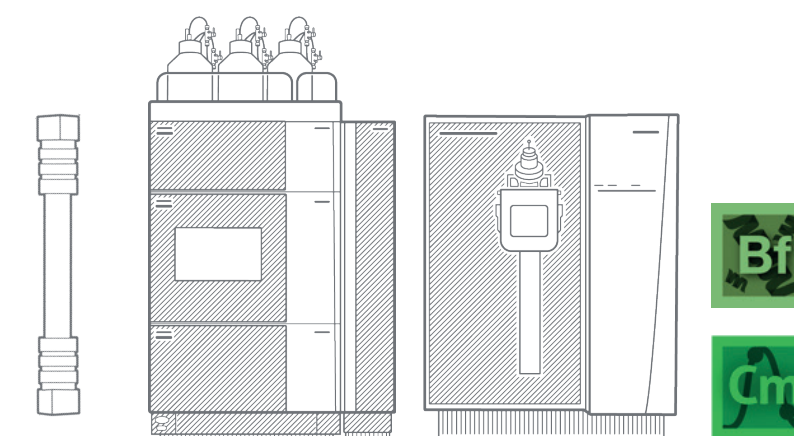

Vanquish Duo UHPLC System & Orbitrap Exploris 480 MS

Accurate mass and resolving power provide the most effective way to accurately and confidently identify peptides. Confident and complete sequence coverage with versatile Thermo Scientific™ BioPharma Finder™ software



## LINKS



Webinar  
*Rapid Automated Peptide Mapping*

Learn more  
*about peptide mapping*

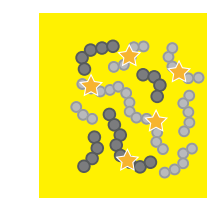





AT A GLANCE

WORKFLOWS

YOUR PARTNER

ANALYSIS

APPLICATION NOTES

RESOURCES

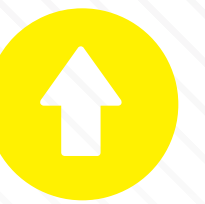

## Multi-Attribute Method

The Multi-Attribute Method (MAM) is a peptide mapping-based approach used to quantify multiple potential CQAs simultaneously. The Thermo Scientific™ MAM 2.0 workflow is a powerful high resolution accurate mass-based workflow that enables comprehensive characterization and monitoring of quality attributes from research to quality control (QC).

MAM is in alignment with the QbD approach to the development of biopharmaceuticals, which is advocated by regulatory agencies and is being adopted by biopharmaceutical companies.







AT A GLANCE

WORKFLOWS

YOUR PARTNER

ANALYSIS

APPLICATION NOTES

RESOURCES

# Multi-Attribute Method

*A platform from discovery and development to QC*

The Multi-Attribute Method (MAM) is a peptide mapping-based method used to quantify multiple potential CQAs simultaneously. Thermo Scientific™ MAM 2.0 is a powerful high resolution accurate mass-based workflow that enables comprehensive characterization and monitoring of quality attributes from research

to quality control (QC). MAM is in alignment with the QbD approach to the development of biopharmaceuticals, which is advocated by regulatory agencies and is being adopted by biopharmaceutical companies.

### Value-added workflow benefits

- Seamless and direct method transfer from lab-to-lab
- End-to-end, compliance-ready platform for deployment from development to QC

- Enterprise software platform for connectivity at global scale leveraging the power of enterprise Chromeleon and Ardia Platform software.
- Confident and consistent attribute identification and monitoring with high resolution and accurate mass data

## CHARACTERIZATION

*Research & Development*

Attribute Characterization | Product Quality Attribute Monitoring

Digestion

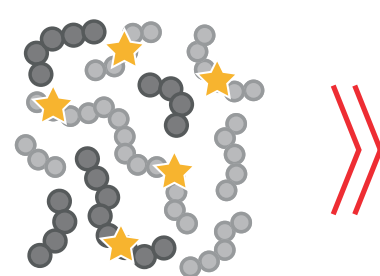

Peptides with or without PTMs

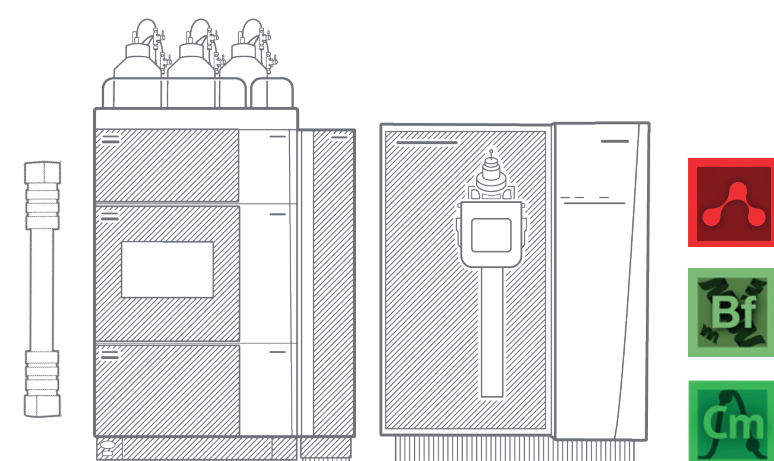

Thermo Scientific™ Vanquish™ Flex or Horizon UHPLC System & Orbitrap Exploris 240 enables comprehensive characterization of product quality attributes



Thermo Scientific™ eWorkflow™

## ROUTINE MONITORING

*Manufacturing & QC*

Critical Quality Attribute Monitoring | New Peak Detection

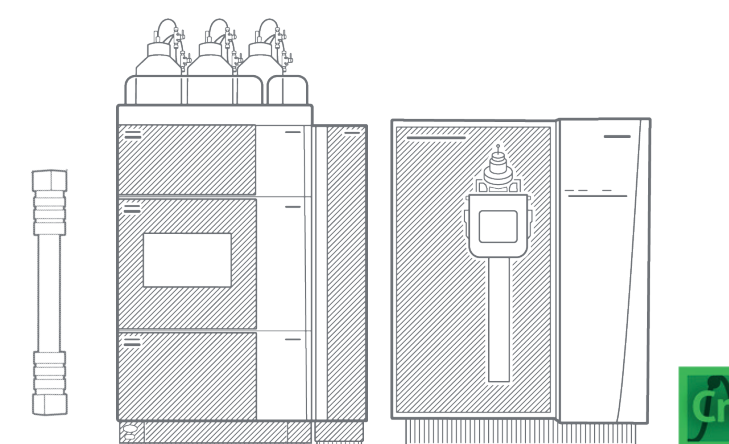

Vanquish Flex or Horizon UHPLC System & Thermo Scientific™ Orbitrap Exploris™ MX enables confident monitoring of critical quality attributes



## LINKS



### Webinar

*Pfizer: Evaluation of the Orbitrap Exploris MX Mass Detector*

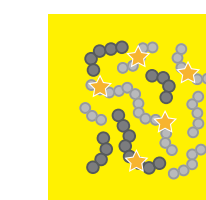

Learn more about multi-attribute method







AT A GLANCE

WORKFLOWS

YOUR PARTNER

ANALYSIS

APPLICATION NOTES

RESOURCES

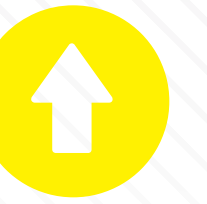

## Host Cell Protein Analysis

The analytical solution for HCP monitoring must be both sensitive and consistent and capable of identifying and quantifying multiple HCPs in a single chromatographic separation.

To meet the growing demand for increased process understanding, scientists are turning to reliable UHPLC systems coupled with HRAM mass spectrometers for accurate and reliable HCP monitoring throughout the purification process.

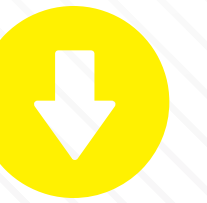





AT A GLANCE

WORKFLOWS

YOUR PARTNER

ANALYSIS

APPLICATION NOTES

RESOURCES

# Host Cell Protein Analysis

*Fast analysis achieved by harnessing the power of Orbitrap technology*

The analytical solution for Host Cell Protein (HCP) monitoring must be both robust and fast, and capable of identifying and quantifying multiple HCPs in a single chromatographic separation. To meet the growing demand for increased process understanding, scientists are turning to reliable UHPLC systems coupled with

HRAM mass spectrometers for accurate and reliable HCP monitoring throughout the purification process.

### Value-added workflow benefits

- Ready-to-use single informatics workflow for peptide mapping and HCP data processing and visualization
- HRAM MS data combined with Thermo Scientific™ Proteome Discoverer™ software provides confident HCP identifications
- Increased sensitivity enabled by micro-flow rate separation allows detection of low abundant HCPs

## CHARACTERIZATION

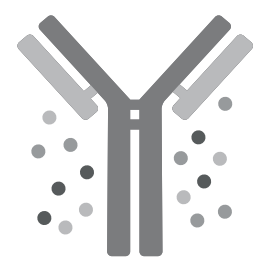

HCPs

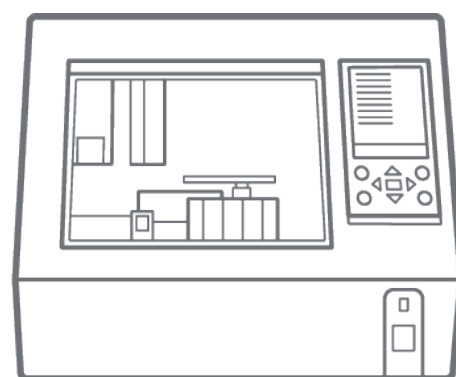
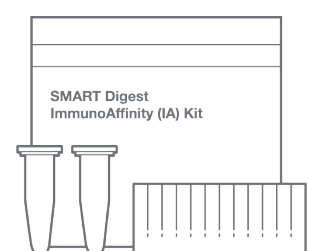

KingFisher Duo Prime Purification System

Non-denaturing protein digestion with SMART Digest kit reduces intra-sample dynamic range and increases host cell protein (HCP) identifications

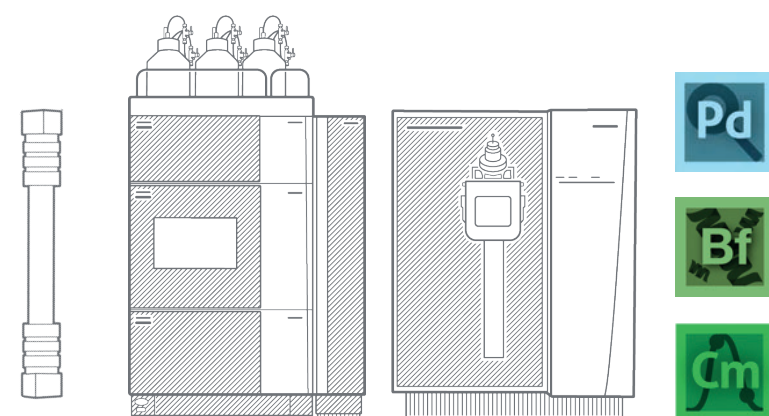

Vanquish™ Duo UHPLC System & Orbitrap Exploris 480 MS

Detection of HCPs ranging in concentrations from <0.5 ppm to 200 ppm  
Identify and quantify multiple HCPs in a single chromatographic separation, allowing for reliable HCP monitoring throughout the purification process

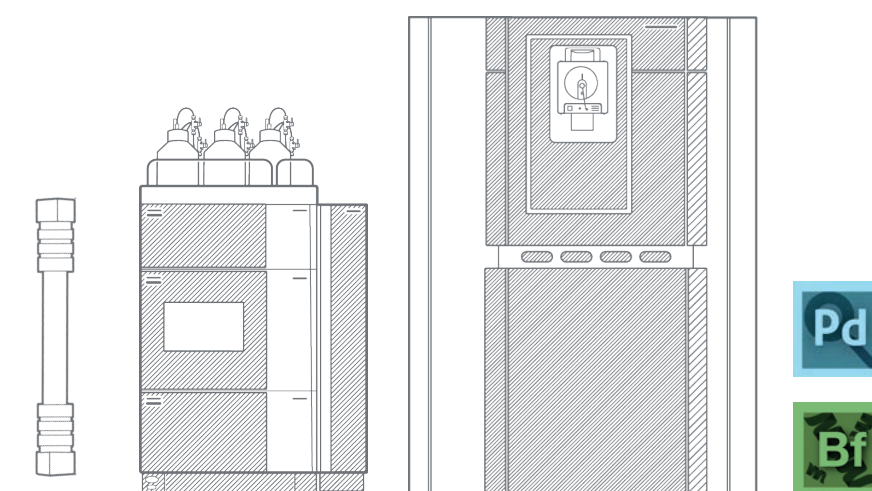

Vanquish Neo Nano LC & Thermo Scientific™ Orbitrap™ Astral™ MS

The Orbitrap Astral Mass Spectrometer helps overcome the challenges of insufficient throughput, low abundant HCP ID and provides sub ppm quantification



## LINKS

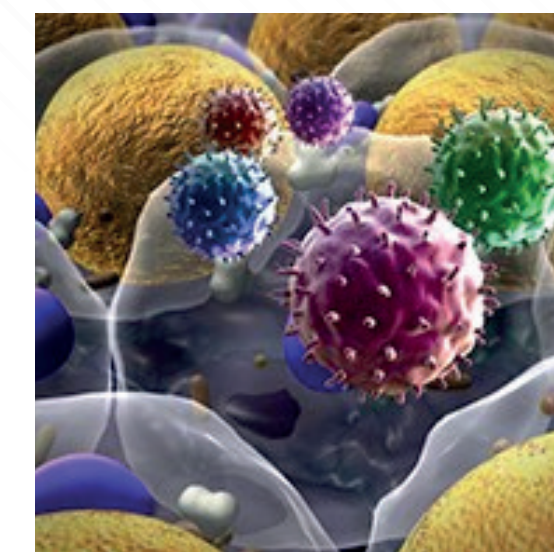

### Video

*Optimized sample preparation for low ppm detection of Host Cell Proteins (HCPs) in biotherapeutics with Orbitrap-based MS detection*

Learn more about host cell protein analysis

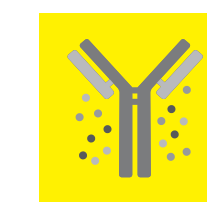





AT A GLANCE

WORKFLOWS

YOUR  
PARTNER

ANALYSIS

APPLICATION  
NOTES

RESOURCES

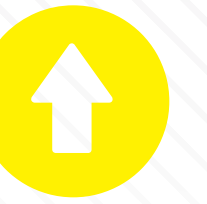

## Glycan Analysis

Analysis of glycans can be complex as no single method will provide all information, but there are many different approaches for glycan analysis.

- Intact Glycoform Analysis
- Labeled Glycan Workflow
- Unlabeled Glycan Workflow
- Glycopeptide Workflow
- Monosaccharide and Sialic Acid Workflow

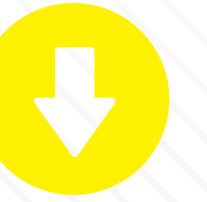





AT A GLANCE

WORKFLOWS

YOUR PARTNER

ANALYSIS

APPLICATION NOTES

RESOURCES



# Glycan Analysis

*Comprehensive toolbox for glycan analysis*

Analysis of glycans can be complex as no single method will provide all information, but there are many different approaches for glycan analysis. Thermo Fisher Scientific offer full solutions to analyze glycans utilizing UHPLC, UHPLC-MS and IC for analysis of glycoforms.

### Value-added workflow benefits

- Flexible solutions for all analytical strategies
- Fit for purpose sample preparation options
- HRAM MS for outstanding intact protein or glycopeptide analysis
- Easy-to use fit for purpose software capabilities from discovery to control

## LINKS



### Webinar

*Advancing carbohydrate analysis - Glycans*

Learn more about glycan analysis

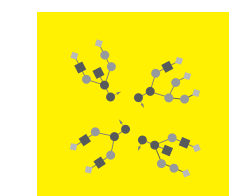

## CHARACTERIZATION

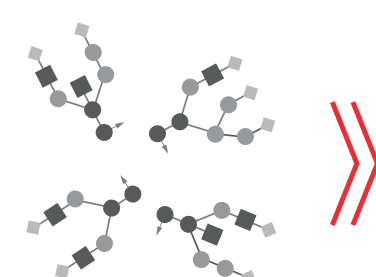

Glycans

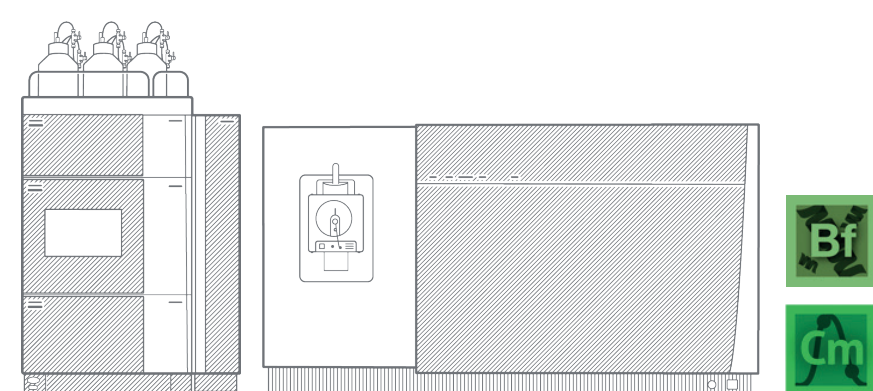

Thermo Scientific™ Orbitrap Ascend™ Tribrid MS

Quantify more samples at lower concentrations using faster acquisition, while achieving greater coverage using a revolutionary new hardware design featuring dual ion routing multipoles

## ROUTINE MONITORING

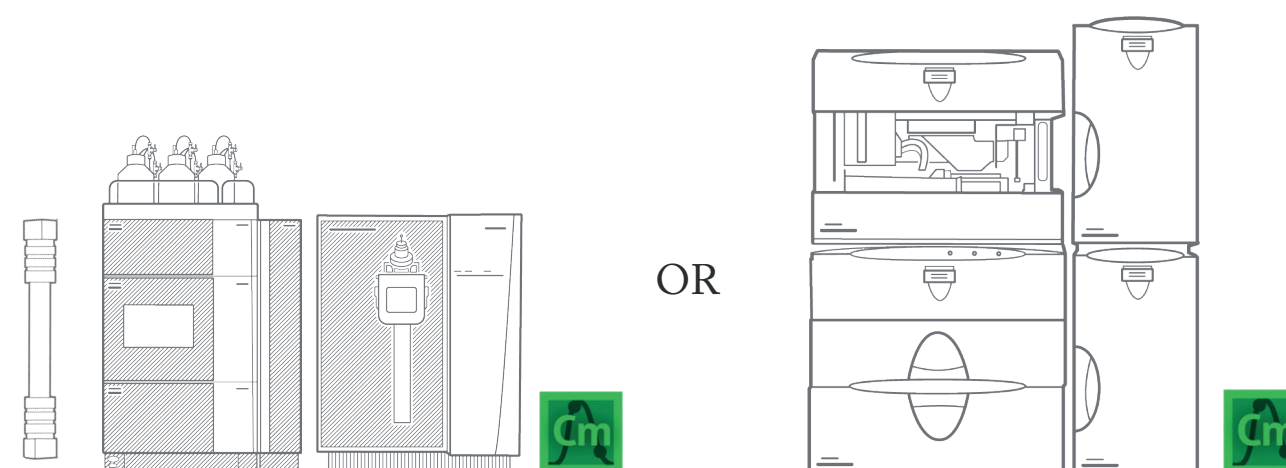

Vanquish UHPLC System & Orbitrap Exploris Platform or Thermo Scientific™ ICS-6000™ Ion Chromatography system

Monitor released N- & O-glycan without labelling  
Flexibility: Ion chromatography with pulsed amperometric detection (HPAE-PAD) OR LC with charged aerosol detection (CAD)







AT A GLANCE

WORKFLOWS

YOUR PARTNER

ANALYSIS

APPLICATION NOTES

RESOURCES



LINKS

# Application Note Spotlight

*Complete characterization of monoclonal antibodies under native and denaturing conditions*

This document provides a comprehensive overview of the use of the Thermo Scientific Orbitrap Exploris 480 mass spectrometer equipped with BioPharma Option for the full characterization of antibody samples. The primary objective is to provide optimal LC-MS conditions to achieve conclusive information on the molecular weight and proteoform heterogeneity at the intact mAb, subunit, and peptide levels.

- A key challenge in analyzing therapeutic monoclonal antibodies (mAbs) is the macro-heterogeneity deriving from various N-linked glycan species and structural heterogeneity deriving from various endogenous modifications. These modifications contribute to micro-heterogenous proteoform mixtures of covalently assembled molecules, which vary in size, charge, and hydrophobicity and could impact mAb chemical properties.
- The solution to this challenge is the application of different workflows for characterizing biopharmaceuticals on the new LC-MS platform, including intact mass analysis under native and denaturing conditions, subunit analysis complemented with Middle-Down analysis, and peptide mapping. The Orbitrap Exploris 480 mass spectrometer equipped with the BioPharma Option is used to achieve these

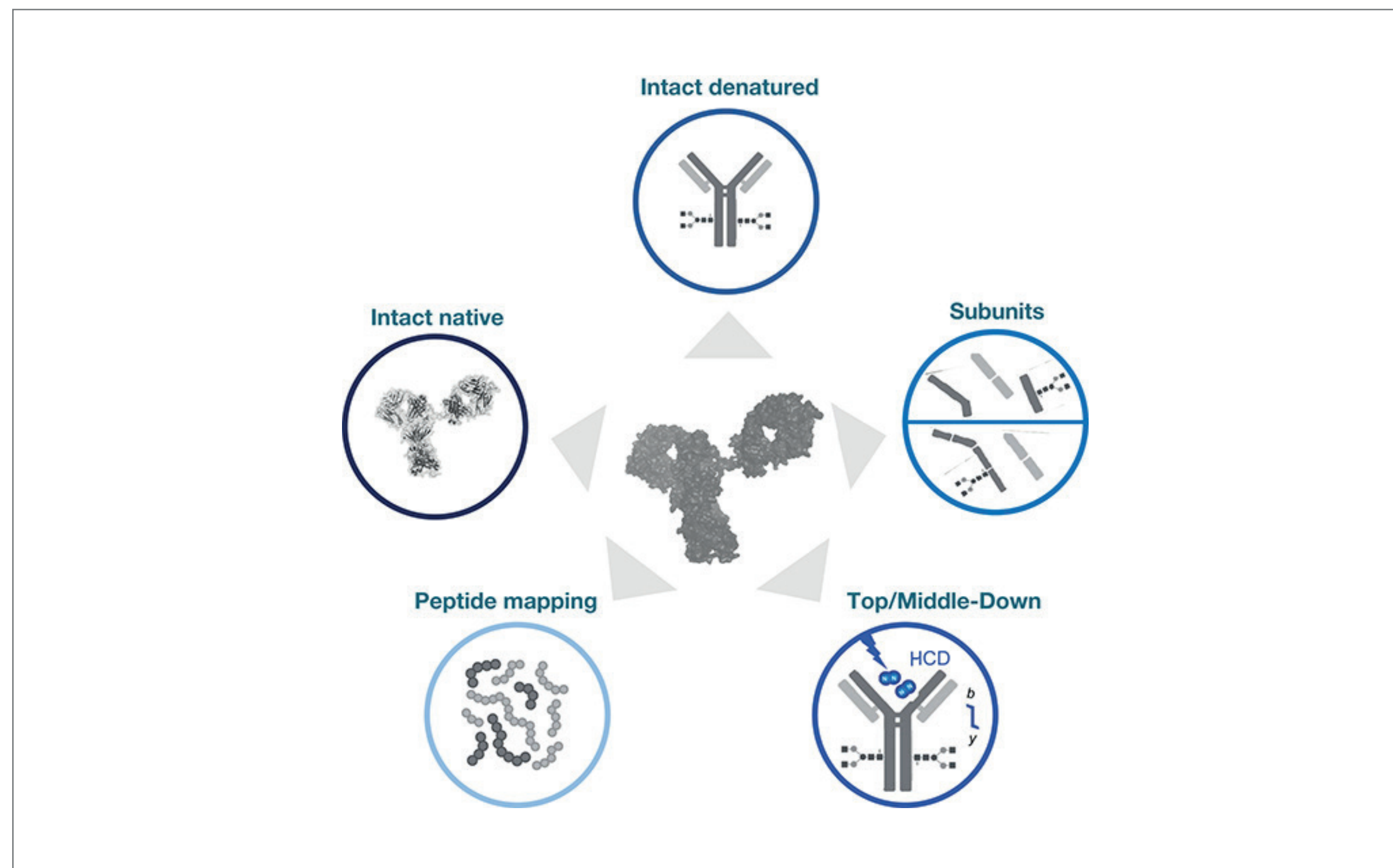

analyses with high sensitivity, scan speed, and resolution to achieve results with the highest confidence.

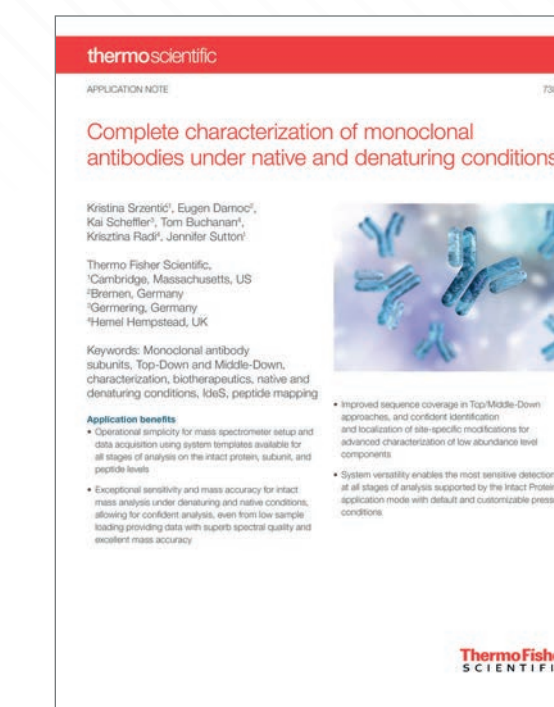

[View the PDF](#)







# Application Note Spotlight

*Seamless LC-MS method transfer in a biopharmaceutical development laboratory*

Symphogen, a Denmark-based biopharmaceutical company, employs an LC-MS system, made up of a Thermo Scientific Vanquish Horizon Duo UHPLC and Thermo Scientific Q Exactive Plus hybrid quadrupole-Orbitrap mass spectrometer, for the development and lead selection studies of complex therapeutic proteins and protein mixtures. Recently, Symphogen aimed to augment their laboratory capabilities by introducing a new generation benchtop Orbitrap-based high-resolution accurate mass (HRAM) mass spectrometer, the Thermo Scientific Orbitrap Exploris 480 mass spectrometer.

- The primary challenge was to ensure the transfer of the execution of the native mass analysis measurements hyphenated to size exclusion chromatography (SEC-MS) from the Q Exactive Plus MS to the new Orbitrap Exploris 480 MS. The new MS platform had to deliver consistent high-quality data, comparable to the existing Q Exactive Plus MS system, across hundreds of samples in each lead selection study.
- The solution involved a systematic evaluation and optimization of method parameters on the Orbitrap Exploris 480 MS to generate high-quality data comparable to the Q Exactive Plus MS platform. Figure 6 shows the assessment

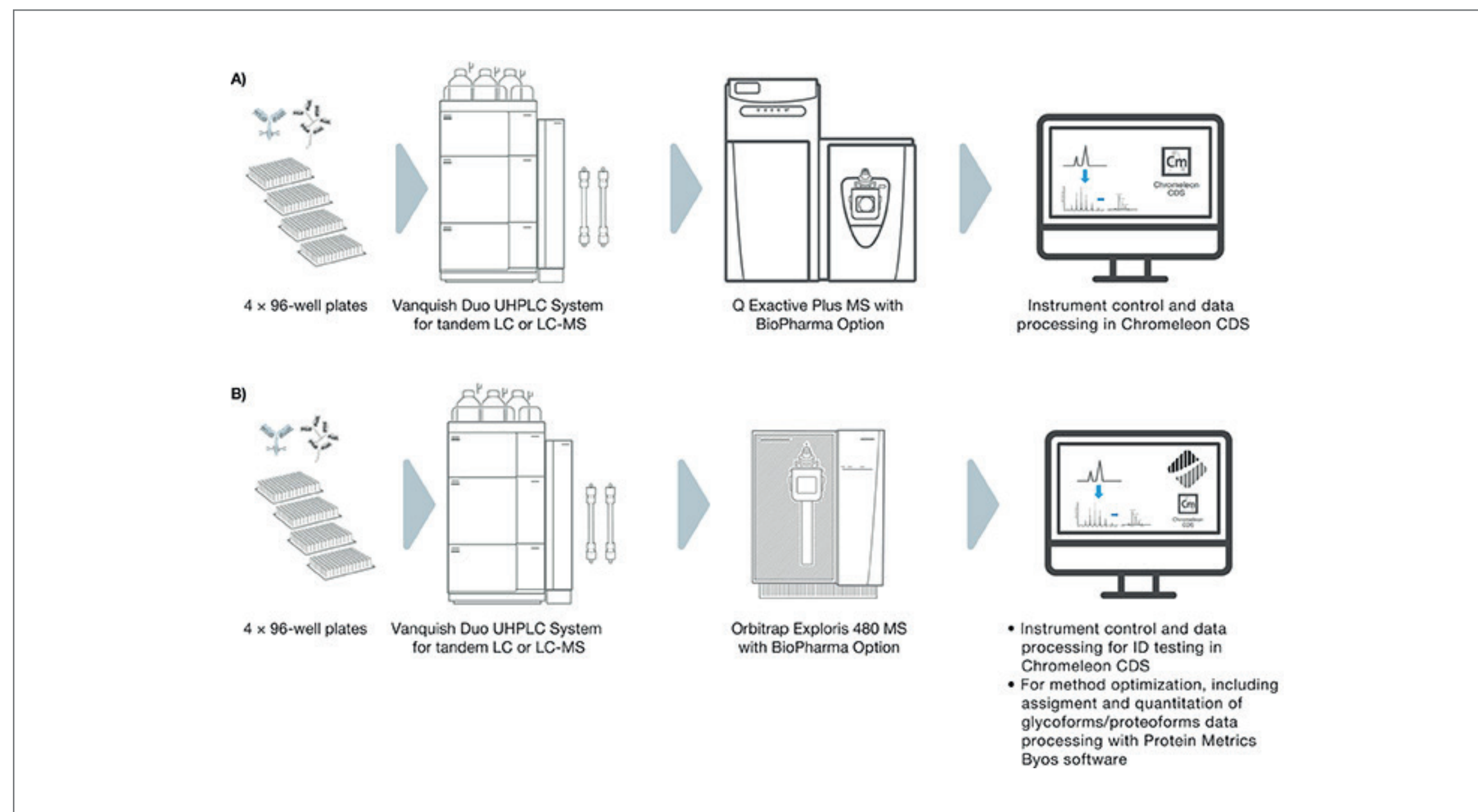

of robustness through the investigation of glycoform level determination reproducibility. The results demonstrate the new platform's robustness, with remarkably low variability and %CV values, thus ensuring a seamless method transfer between the two platforms.



[View the PDF](#)







AT A GLANCE

WORKFLOWS

YOUR PARTNER

ANALYSIS

APPLICATION NOTES

RESOURCES



LINKS

# Application Note Spotlight

*Confident peptide mapping and disulfide bond analysis of an IgG2 monoclonal antibody*

The document discusses an application brief related to peptide mapping and disulfide bond analysis of an IgG2 monoclonal antibody, denosumab, using the Thermo Scientific Orbitrap Exploris 240 mass spectrometer. The primary goal was to demonstrate the utility and capability of the mass spectrometer for the routine characterization of biotherapeutics through LC-MS peptide mapping. This procedure allows for the full sequence coverage, high confidence in low level post-translational modifications (PTMs) identification, and ease in interpreting complex data

- The major challenge in the biopharmaceutical industry is ensuring the quality, efficacy, and safety of biotherapeutic proteins, such as monoclonal antibodies, due to variations in production processes and the intrinsic complexity of these proteins. There are many critical quality attributes (CQAs) that must be monitored, including the detection of inter- and intrachain disulfide bonds and low-level post-translational modifications (PTMs). Additionally, the industry requires instruments and analytical methods that can be transferred and adopted routinely across organizations.
- The Orbitrap Exploris 240 mass spectrometer provides operational simplicity and flexibility, enabling a wide range

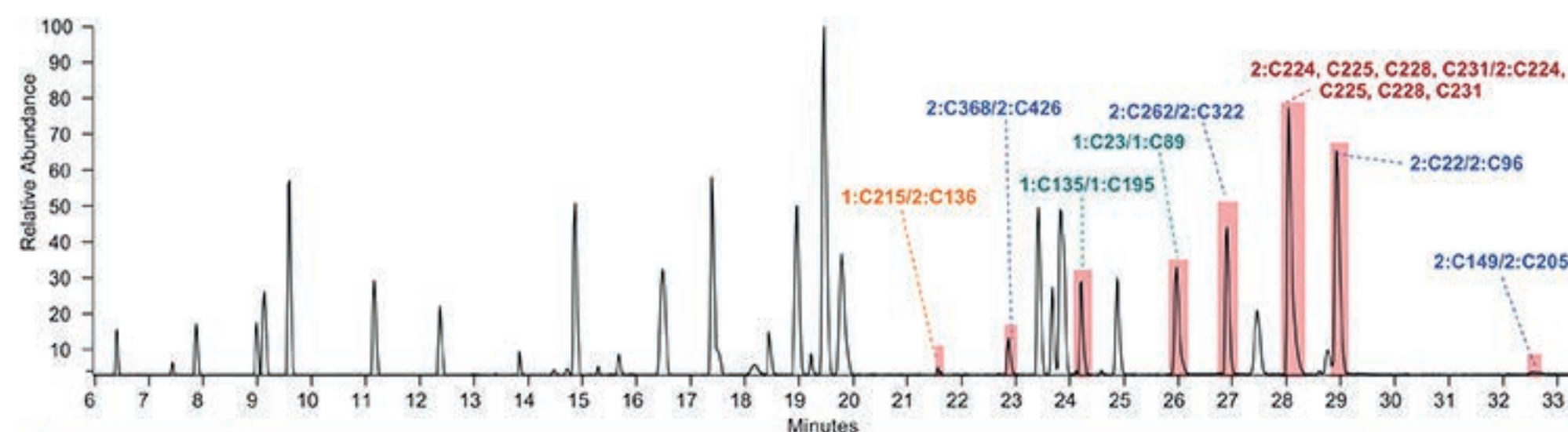

S-S bond type	Peptide sequence	Position	Δ ppm	RT
Intrachain	LC1 ATLS <sup>C</sup> CR / LEPEDFAV <sup>F</sup> Y <sup>C</sup> QQY <sup>G</sup> SS <sup>P</sup> PR	1:C23/1:C89	-1.2	25.95
	LC2 SGTASV <sup>V</sup> CL <sup>L</sup> LN <sup>N</sup> FY <sup>P</sup> R / HKVY <sup>A</sup> CEV <sup>T</sup> HQ <sup>L</sup> SL <sup>S</sup> SP <sup>V</sup> TK	1:C135/1:C195	-2.1	24.15
	HC1 LSCA <sup>A</sup> SG <sup>F</sup> T <sup>F</sup> SS <sup>Y</sup> AM <sup>S</sup> W <sup>R</sup> / AEDTAV <sup>Y</sup> Y <sup>C</sup> AK	2:C22/2:C96	-2.7	28.95
	HC2 STSE <sup>S</sup> TAAL <sup>G</sup> CL <sup>V</sup> K / DYF <sup>P</sup> EP <sup>V</sup> TV <sup>S</sup> W <sup>N</sup> SG <sup>A</sup> L <sup>T</sup> SG <sup>V</sup> H <sup>T</sup> FPA <sup>V</sup> LQ <sup>S</sup> SL <sup>Y</sup> SL <sup>S</sup> V <sup>V</sup> TP <sup>S</sup> SN <sup>F</sup> G <sup>T</sup> Q <sup>T</sup> Y <sup>T</sup> C <sup>N</sup> V <sup>D</sup> H <sup>K</sup> PS <sup>N</sup> TK	2:C149/2:C205	-0.9	32.54
Interchain	HC3 TPE <sup>V</sup> TC <sup>V</sup> V <sup>V</sup> D <sup>V</sup> SH <sup>E</sup> DPE <sup>V</sup> Q <sup>F</sup> N <sup>W</sup> Y <sup>V</sup> DG <sup>V</sup> EV <sup>H</sup> NA <sup>K</sup> / CK	2:C262/2:C322	-0.6	26.76
	HC4 NQ <sup>V</sup> SL <sup>T</sup> CL <sup>V</sup> K / WQ <sup>Q</sup> GN <sup>V</sup> F <sup>S</sup> CS <sup>V</sup> M <sup>H</sup> EAL <sup>H</sup> NHY <sup>T</sup> Q <sup>K</sup>	2:C368/2:C426	0.4	22.87
	LC-HC GEC / GPS <sup>V</sup> F <sup>L</sup> AP <sup>C</sup> SR	1:C215/2:C136	-2.5	21.86
	Hinge KCC <sup>V</sup> EC <sup>P</sup> PC <sup>P</sup> APP <sup>V</sup> AG <sup>S</sup> V <sup>L</sup> F <sup>L</sup> PP <sup>K</sup> PK / KCC <sup>V</sup> EC <sup>P</sup> PC <sup>P</sup> APP <sup>V</sup> AG <sup>S</sup> V <sup>L</sup> F <sup>L</sup> PP <sup>K</sup> PK	2:C224, C225, C228, C231/2:C224, C225, C228, C231	-0.02	28.05

of characterization assays to be performed with high confidence. It was used to perform peptide mapping analysis to confirm 100% sequence coverage of denosumab, enabling the detection of low-level PTMs and the location of disulfide bonds.

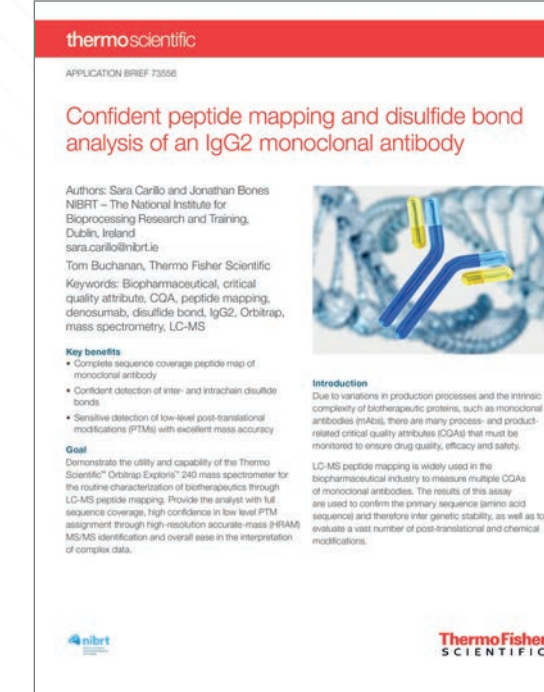

View the PDF







AT A GLANCE

WORKFLOWS

YOUR PARTNER

ANALYSIS

APPLICATION NOTES

RESOURCES



LINKS

# Application Note Spotlight

*IdeS-cleaved mAb subunit analysis with LC-HRAM-MS: a quick and accurate comparison of biosimilar and originator biotherapeutics*

The document discusses the application of a middle-up approach for the characterization of biotherapeutics, using the Thermo Scientific Q Exactive Plus Hybrid Quadrupole-Orbitrap mass spectrometer. This technique is crucial for the fast and reliable characterization of monoclonal antibody variants and modifications, which is of paramount importance in the biopharmaceutical industry.

- The key challenge in the biopharmaceutical industry is to establish the quality and safety of biosimilar therapeutics, which are drugs with minimal variations from their originator. These variations can occur due to multiple factors, including expression system, growing conditions, purification steps, or final formulations. Therefore, it is crucial to monitor and quantify these variations to correlate them to any potentially different in vivo activity, such as different clearance time or other interactions within the patient.
- The solution to this challenge is the use of a middle-up approach, which involves the use of liquid chromatography hyphenated with high-resolution, accurate-mass spectrometry (LC-HRAM-MS) for the comparison of monoclonal antibody drug substances and their respective biosimilars.

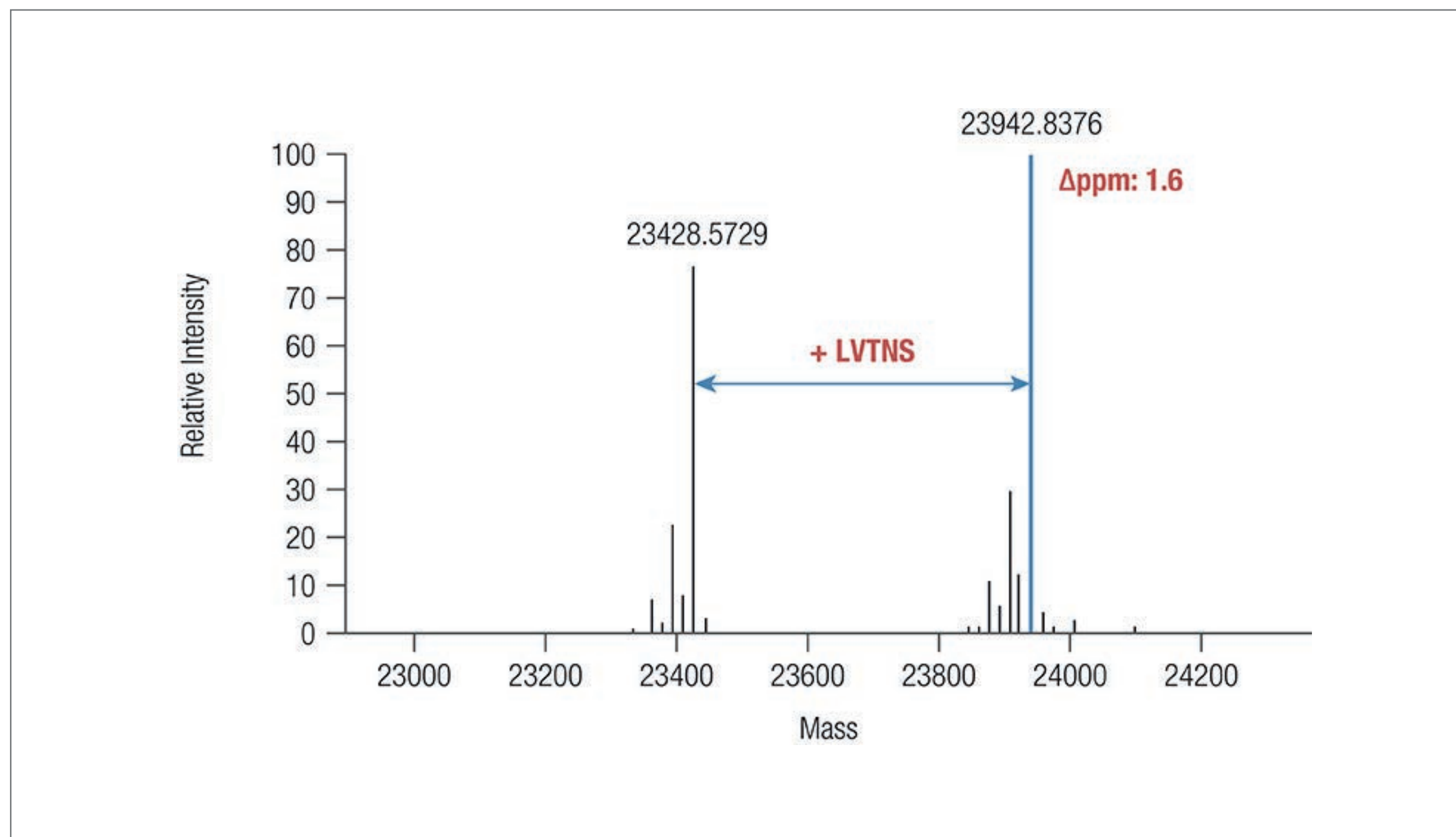

This approach minimizes sample handling and artifacts and provides quicker or complementary information. As illustrated in Figure 2, the LC-MS analysis of IdeS digested bevacizumab biosimilar provided high quality data, which

allowed for a confident identification and sequence verification of light chain and Fd region and a rapid analysis of Fc region variants, including glycoform and N-terminal lysine loss.



View the PDF







AT A GLANCE

WORKFLOWS

YOUR PARTNER

ANALYSIS

APPLICATION NOTES

RESOURCES



LINKS

# Application Note Spotlight

## Proton transfer charge reduction (PTCR)

This document provides a comprehensive overview of the experiments conducted for the analysis of monoclonal antibody (mAb) subunits under denaturing conditions. The experiments utilize Liquid Chromatography (LC) and Mass Spectrometry (MS) analysis with various reagents, columns, solvents, and flow rates. The document details the LC conditions, MS conditions, data analysis, results, and discussion.

- The primary challenge in this context is the characterization of the primary sequence of biotherapeutics, specifically monoclonal antibodies (mAbs). Traditional methods such as Bottom-Up Mass Spectrometry (BU MS) and Top-Down Mass Spectrometry (TD MS) have limitations in terms of sequence coverage and the complexity of MS2 spectra, especially for larger mAb subunits.
- The solution proposed in this document is the application of Proton Transfer Charge Reduction (PTCR) in conjunction with Electron Transfer Dissociation (ETD) for middle-down analysis of mAbs. This approach simplifies fragment ion spectra, leading to improved sequence coverage and increased confidence in product ion matching.

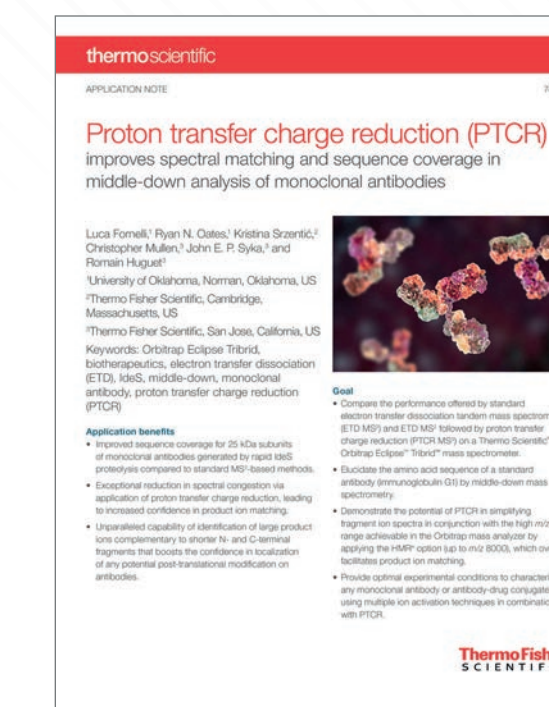
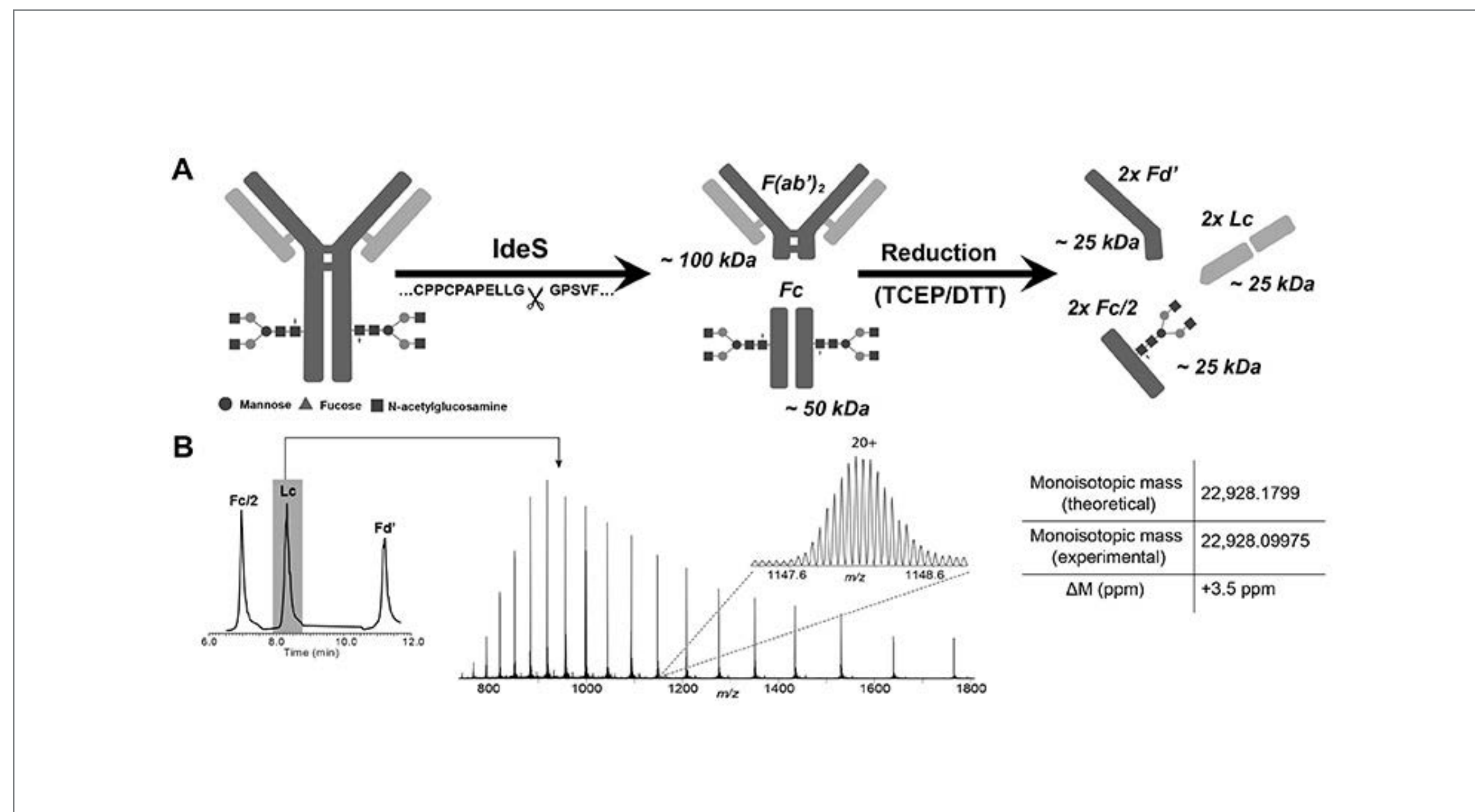

View the PDF







AT A GLANCE

WORKFLOWS

YOUR PARTNER

ANALYSIS

APPLICATION NOTES

RESOURCES

## Resources

*BioPharma Learning Center*

[Peptide Mapping](#)

[Glycan Analysis](#)

[Host Cell Protein Analysis](#)

[Subunit Analysis](#)

[Native Intact Mass Analysis](#)

[Protein Aggregate Analysis](#)

[Charged Variant Analysis](#)

[Multi-Attribute Method](#)

[Higher Order Structure Analysis](#)

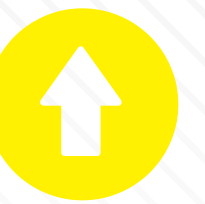

### LINKS

Protein  
Homepage

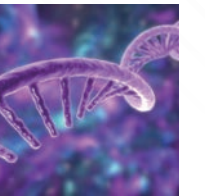

Find the  
column  
for your  
application



Biopharma  
Webinar  
Portal  
Searchable by  
application

